

Part # 000930, 000934

CAUTION: NOT ALL VEHICLES CONFORM TO PUBLISHED SPECIFICATIONS! TEST FIT THIS ASSEMBLY IN YOUR TRUCK BEFORE PAINTING OR ALTERING IN ANY WAY. ONLY ASSEMBLIES IN NEW CONDITION WILL BE ACCEPTED FOR RETURN OR EXCHANGE.

REMOVAL:

1. Engage the steering column / ignition switch lock with the steering wheel & wheels centered. (NOTE It may be necessary to remove the upper bolt prior to locking ignition for accessibility)
2. Disconnect the factory rag joint at the steering box end of the assembly. Remove the two bolts that hold the rag joint to the stock steering shaft. The two safety pins may have to be backed out to allow the flange to clear them.
3. Now disconnect the coupler at the other end of the assembly by removing the bolt and remove the entire stock assembly. This connection is often rusted and may require some penetrating oil or a few taps with a hammer.

INSTALLATION:

4. With the Borgeson shaft fully collapsed bolt the rag joint end of the assembly to the existing rag joint half on the steering box. After tightening the two bolts be sure to return the two safety pins to their original position.
5. Extend the Borgeson shaft to allow installation of the universal joint onto the splined or Double D shaft on the steering column. Install the universal joint onto the shaft to the depth shown in Figure B.
6. SPLINED COLUMN #000930: A seat must be provided for the set screw as shown in Figure A. (NOTE The existing factory flat will not be used) Tighten the set screw to mark the shaft and then remove the universal joint to file a new flat spot on the splined shaft. Tighten the set screw into the seat and then tighten the lock nut.

DOUBLE-D COLUMN #000934: The universal joint will be secured with two set screws as shown in Figure C. Install the universal joint to the depth shown in Figure B. Tighten the short set screw against the shaft. The longer of the set screws must pass through one wall of the tube only. If the long set screw does not line up with an existing hole in the tube, a 3/8" diameter hole must be drilled through one wall of the tube only. Remove the universal joint before drilling the hole; do not drill through the universal joint. The set screw should pass through this hole and bear against the opposite wall of the tube. Tighten both set screws and then tighten lock nuts.

7. After approximately 100 miles, retighten all set screws and then lock nuts. If you wish to use a product such as Loctite, we recommend Loctite 222 for ease of removal.

*Part #000941 Replacement Rag Joint disc with hardware is available if your stock is too worn to reuse.

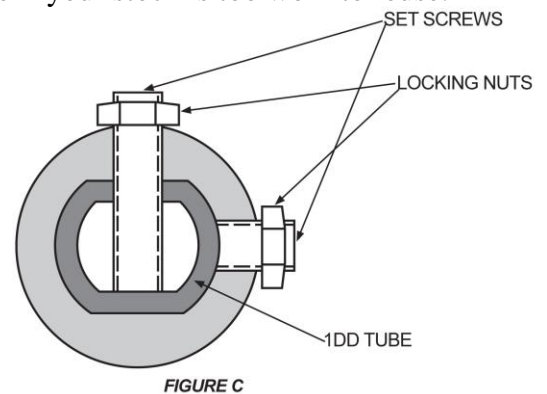
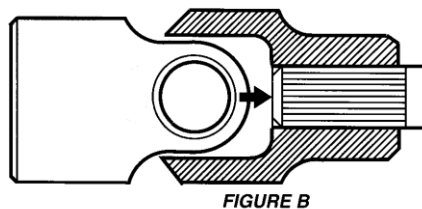
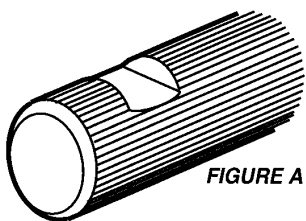

Borgeson Universal Co., Inc.
9 Krieger Dr. Travelers Rest, SC 29690
www.borgeson.com